

CERTIFICATION

This torque wrench as calibrated at the factory, is certified to meet the current ASME specification. Additionally, all wrenches are calibrated on a torque standard traceable to the National Institute of Standards and Technology (N.I.S.T.).

CONVERSION TABLE

To Convert From	To	Multiply By
in. oz.	in. lb.	0.06250
in. lb.	in. oz.	16
in. lb.	ft. lb.	0.08333
in. lb.	cmkg	1.15212
in. lb.	mkg	0.01152
in. lb.	Nm	0.11298
in. lb.	dNm	1.12984
ft. lb.	in. lb.	12
ft. lb.	mkg	0.13825
ft. lb.	Nm	1.35581
dNm	in. lb.	0.88507
dNm	Nm	0.1
Nm	dNm	10
Nm	cmkg	10.1971
Nm	mkg	0.10197
Nm	in. lb.	8.85074
Nm	ft. lb.	0.73756
cmkg	in. lb.	0.86796
cmkg	Nm	0.09806
mkg	in. lb.	86.7961
mkg	ft. lb.	7.23301
mkg	Nm	9.80665

FOR YOUR PERMANENT FILE

WRENCH MODEL NUMBER:

WRENCH SERIAL NUMBER:

For Warranty Claims, Contact CDI Torque Products
at (626) 965-0668.

LIMITED WARRANTY

The CDI Pre-Set Torque Wrench is backed by a one year warranty. This warranty covers manufacturer defects and workmanship. The warranty excludes misuse, abuse and normal wear and tear. Exclusion is not allowed in some states and may not apply. This warranty gives you specific legal rights, and you may have other rights, which vary from state to state.



Please Recycle

IMPORTANT ENVIRONMENTAL NOTES:

1. This equipment may contain hazardous materials which can be harmful to the environment.
 2. Do not dispose of this equipment as municipal waste. Return it to the distributor or a designated collection center.
- Thank you for caring about our environment!

CDI TORQUE PRODUCTS

A Snap-on Specialty Tools Brand

19220 SAN JOSE AVENUE • CITY OF INDUSTRY, CA 91748 • USA
(626) 965-0668

Find other fine torque products at WWW.CDITORQUE.COM

Form 20-30-CDI
6/2010 Rev. B

OPERATION MANUAL

PRE-SET TORQUE WRENCH



CDI TORQUE PRODUCTS

SAFETY MESSAGES



WARNING



Read operation manual completely before using torque instrument and store for future reference.



Wear safety goggles-both user and bystanders



- An out of calibration torque wrench can cause part or tool breakage
- Periodic re-calibration is necessary to maintain accuracy
- Do not exceed rated torque as overtorquing can cause wrench or part failure
- Do not use torque instrument to break fasteners loose



- Do not use cheater extension on the handle to apply torque
- Broken or slipping tools can cause injury.



CAUTION - RATCHET HEAD

Ratchet mechanism may slip or break if dirty, mismatched or worn parts are used, or direction lever is not fully engaged. Ratchets that slip or break can cause injury.

ADJUSTMENTS OF TORQUE SETTINGS

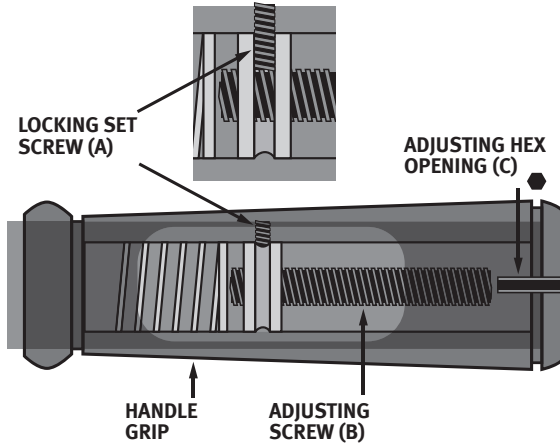

SETTING TORQUE

1. To set the torque values, loosen locking set screw (A) with a 3/32" hex wrench.
2. Insert interchangeable plain drive head (D) (*consult factory for model number*) into receptacle (F) until the locking pin (E) is fully engaged with the corresponding receptacle hole. (See Figure I)
3. Place a T-handle hex wrench through adjusting hex opening (C) at rear of handle grip until engaging the adjusting screw (B).
4. Place the wrench on a torque tester. Turn adjusting screw (B) with the T-handle hex wrench clockwise to increase torque and counter-clockwise to decrease torque.
5. To set torque, apply a slow steady force on the pre-set wrench. Turn adjusting screw (B) until the desired torque setting is displayed on the torque tester.
6. Tighten the locking set screw to 10 in. lbs. (A). To ensure that wrench setting is repeatable, cycle three more times. If the readings are not as desired, repeat steps 1-5.

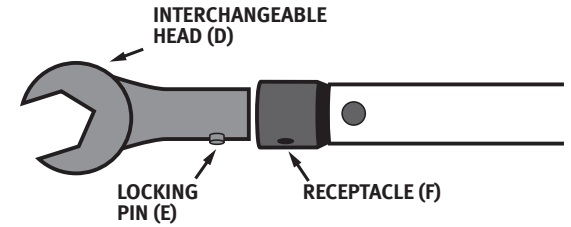
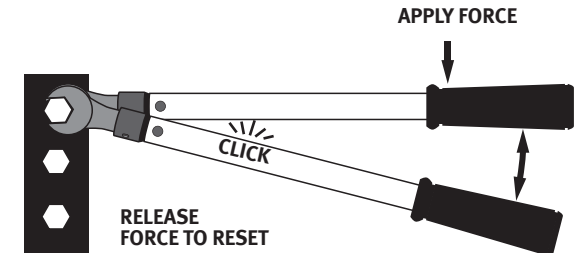

Figure I

NOTE:

- Some interchangeable heads used in pre-set torque wrenches have lengths that vary.
- It is recommended that the pre-set torque wrenches are to be calibrated with the interchangeable head that is to be used to assure the greatest accuracy in calibration.
- Hex wrenches used to adjust torque settings will vary in length.

To verify calibration or to torque a fastener, keep hand centered on the handle grip. Apply a slow force until a click/impulse is heard or felt. Stop and allow the wrench to reset.



MAINTENANCE / SERVICE

1. The torque wrench's internal mechanism is permanently lubricated during assembly. **Do not attempt to lubricate the internal mechanism.**
2. Clean torque wrench by wiping. **Do not immerse.**
3. Store torque wrench in protective tube at its lowest torque setting. **Do not force handle below lowest setting.**